



Item No. _____

C612

Combination Freezer

Single Shake, Single Soft Serve, Simplified Pump,
Hopper Agitation

Features

Offer all the popular shake and soft serve variations, from low fat shakes, smoothies, and low or non-fat ice creams to custards, yogurt, and sorbet. Direct-draw a single flavor shake or blend in flavorings for more variety.

Freezing Cylinder

Shake side, 7 quart (6.6 liter). Soft Serve side 3.4 quart (3.2 liter).

Mix Hopper

Two, 20 quart (18.9 liter). Refrigerated to maintain mix below 41°F (5°C). Air/mix pumps deliver the precise amount of air and mix to the freezing cylinder.

Indicator Lights and Audible Alarms

Mix Low light and operator-enabled audible alarm alert the operator to add mix. When the Mix Out light flashes, the unit automatically goes into Standby mode to prevent damage.

Touch Screen Controls

Microprocessor touch controls are embedded in durable tempered glass panel. Viscosity is continually measured to dispense consistent quality shake and soft serve desserts. Temperatures in the hoppers or freezing cylinders may be displayed at any point of operation. Draw counter allows operator to view number of servings dispensed.

Dispensing

Ergonomic draw handles. Star design pattern is integrated into the soft serve dispensing door, reducing operator replacement parts.

Door Interlock System

Protects the operator from injury as the beater will not operate without the dispensing door in place.

Two Locking Casters

Front casters have a locking feature for operators to keep equipment in place. The lock can be released to move the equipment for cleaning.



Shown with Optional Panel Spinner

C612

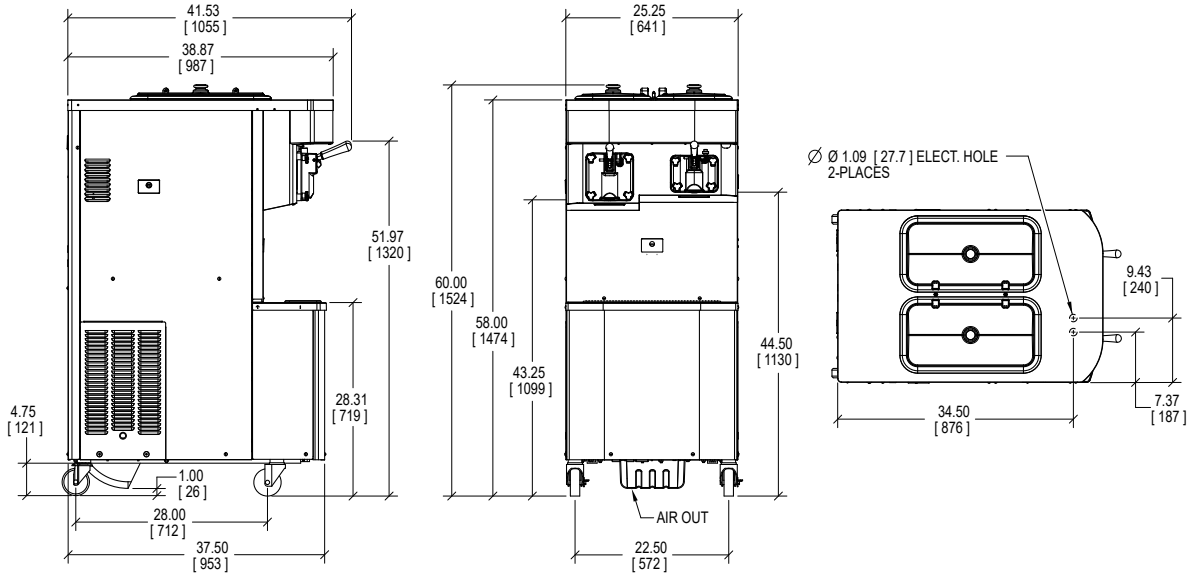

FIGURES IN BRACKETS INDICATE MILLIMETERS / DECIMAL AND FRACTIONAL DIMENSIONS EQUAL TO (PLUS OR MINUS 1/16 INCH [1.5 mm]).

Weights	lb	kg
Net	700	317.5
Crated	850	385.5

*For reference only

	cu. ft.	cu. m.
Volume	61.8	1.75

Dimensions	in.	mm
Width	25-1/4	641
Depth	38-7/8	987
Height	60	1,524
Floor Clearance	4-3/4	121

*Mounted on standard casters

Electrical	Maximum Fuse Size		Minimum Circuit Ampacity		Poles (P) Wires (W)
	Left	Right	Left	Right	
208-230/60/1	30	25	24	20	2P 3W
208-230/60/1*	35	25	25	20	2P 3W
208-230/60/3	25	20	18	25	3P 4W
208-230/60/3*	25	20	19	15	3P 4W

* Electrical ratings when unit employs spinner motor

This unit may be manufactured with other electrical characteristics and may have additional regulatory agency approvals. Consult the local Taylor distributor for other electrical characteristics and agency approvals based on specific electrical and country requirements.

(For exact electrical information, approval marks and refrigerant, always refer to the data label of the unit.)

Continuing research results in steady improvements; therefore, these specifications are subject to change without notice.

Bidding Specs

Electrical: Volt _____ Hz _____ ph _____
 Neutral: Yes No Cooling: Air Water NA

Options: _____

Specifications

Electrical

Two dedicated electrical connections are required. See the Electrical chart for the proper electrical requirements. Manufactured to be permanently connected. Consult your local Taylor distributor for cord & receptacle specifications as local codes allow.

Beater Motor

Shake, 1.0 hp; Soft Serve, 1.5 hp
 Refrigeration System
 Shake, 11,000 BTU/hr.; Soft Serve, 9,500 BTU/hr. R449A
 Separate Hopper Refrigeration (SHR), One, 400 BTU/hr. R134A.
 (BTUs may vary depending on compressor used.)

Air-Cooled

Minimum 3" (76 mm) around all sides. Install the deflector provided to prevent recirculation of warm air. Minimum air clearances must be met to ensure adequate airflow for optimum performance.

Options

- Panel-mounted spinner

Accessories

- Disc spinner - 3 spoke

Authorized Taylor Distributor



750 N. Blackhawk Blvd.
 Rockton, Illinois 61072
www.taylor-company.com